

Auckland Museum

TE MAHI KAI
Maori Food Gathering

education kit

Tamaki Paenga Hira

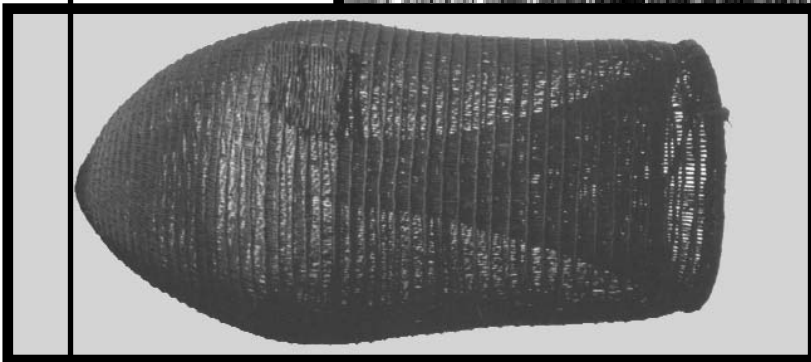

ACTIVITY SHEETS YEARS 1 TO 10

©Auckland Museum 2005

	<i>page</i>
About this Resource	1
Booking Information	1
Introduction	2
SECTION 1	
Background Notes	3
SECTION 2	
Curriculum Links	
SECTION 3	
Gallery Activity Sheets	7

ABOUT THIS RESOURCE:

This resource is designed to support Social Studies classes of all levels, and may also be used by teachers of science, history and technology.

Further resources are available, dealing with:

- He Taonga Maori (Maori Treasures)*
- Te Ao Kohatu O Te Maori (Maori Technology)*
- Te Ao Turoa (Maori Natural History)*
- Whakaraka (traditional Maori games and pastimes)*
- Whakairo Tuturu Maori (carving)*
- Tukutuku Tuturu Maori*
- Kowhaiwhai Tuturu Maori*
- Raranga Tuturu Maori (weaving)*

Adult/child interaction is important to maximise your museum experience. Group leaders need to have some background knowledge of what the students are expected to cover and they are advised to participate in the introduction on arrival.

BOOKING INFORMATION:

All school visits to the museum must be booked. We advise booking 2–3 months in advance.

Numbers:

He Taonga Maori Galleries
90 maximum (including adults)

Hands-On Sessions
35 maximum students.

Adult/child ratio:

Y 1–4	1:6
Y 5–6	1:7
Y 7–8	1:10
Y 9–10	1:30

Booking:

Contact the Museum School Bookings Officer at:
Private Bag 92018 Auckland
Phone: (09) 306 7040
Fax: (09) 306 7075

Introductions and Hands-on Sessions facilitated by Education Staff are available. Please ask the School Bookings Officer for more information.

Auckland Museum Education kits may be downloaded free at www.aucklandmuseum.com

Introduction

AN INTRODUCTION TO TE MAHI KAI

When Maori tupuna (ancestors) arrived in temperate Aotearoa, they brought traditional cultivated plants from a tropical environment. The new land provided different birds and fish but little in the way of mammals. In order to feed themselves, the new arrivals required new skills and knowledge.

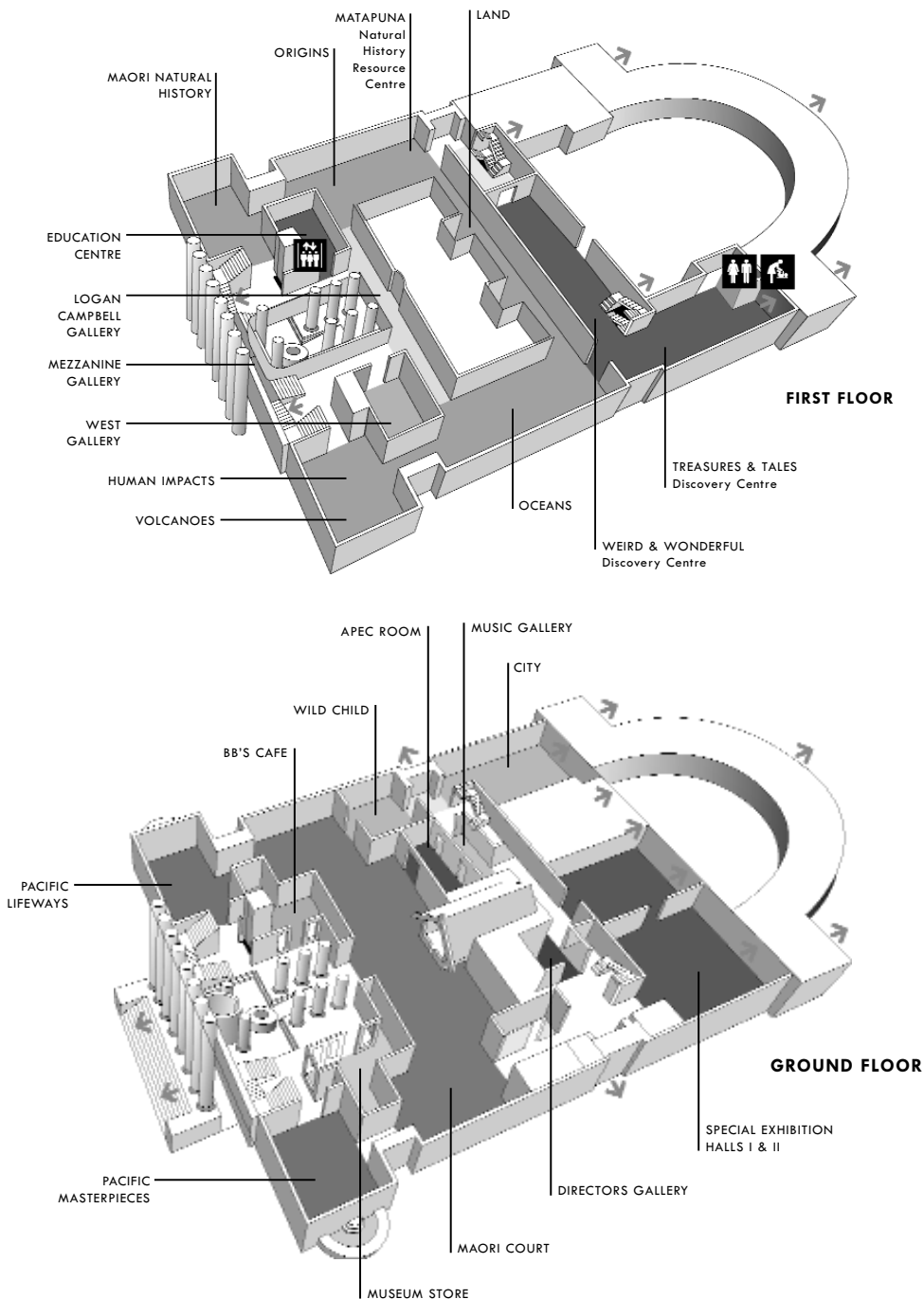

Gallery Activity Sheet

Y1-3

te mahi kai

M AORI GALLERIES (GROUND FLOOR)

1. Pataka

Find a building that has legs. This was built by Maori to store food in. The legs stopped animals getting inside. Why didn't they want animals to get inside the food house?

2. Pa model

Find:

- people working in kumara gardens
- people fishing
- an animal that could be used to hunt birds

3. Fishing

You are to catch fish for the tribe. Find something you would use to catch a really big fish. What else could you use to catch fish?

4. Birding

Maori used to catch birds to eat, just like people now eat chicken. The traps for catching birds often had loops to tighten round their neck or legs. Find some bird traps.

5. Gourd

You have been asked to collect water for the tribe. Find something that would be good for carrying water in.

M AORI NATURAL HISTORY GALLERY (TE AO TUROA - MIDDLE FLOOR)

1. Gardens

Find some food Maori grew in their gardens. Have you eaten any of this food?

You are going to help out in the gardens, find some tools you would use. What are they called?

Draw a picture of one of them.

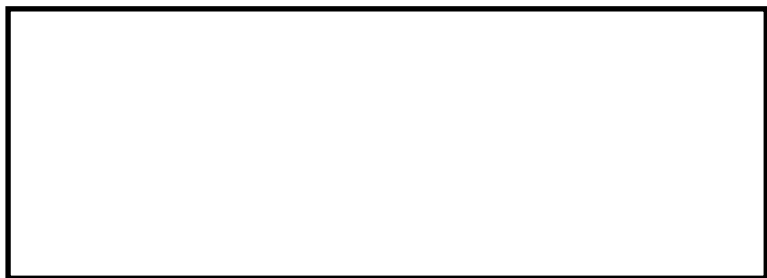

2. Hangi

Find the hangi.

You are going to make a hangi to cook the food for the tribe. First you dig a big hole and make a fire in the bottom of the hole. What else do you put in the hole?

3. Fire

Watch the fire video to see how the fire was made to heat the stones that cooked the hangi.

4. Freshwater fish

Look in the running water to find a silve animal that Maori liked to eat

Continue into the rest of the Natural History Gallery to find a very big bird that was eaten by Maori.

te mahi kai

Gallery Activity Sheet

Y1-3

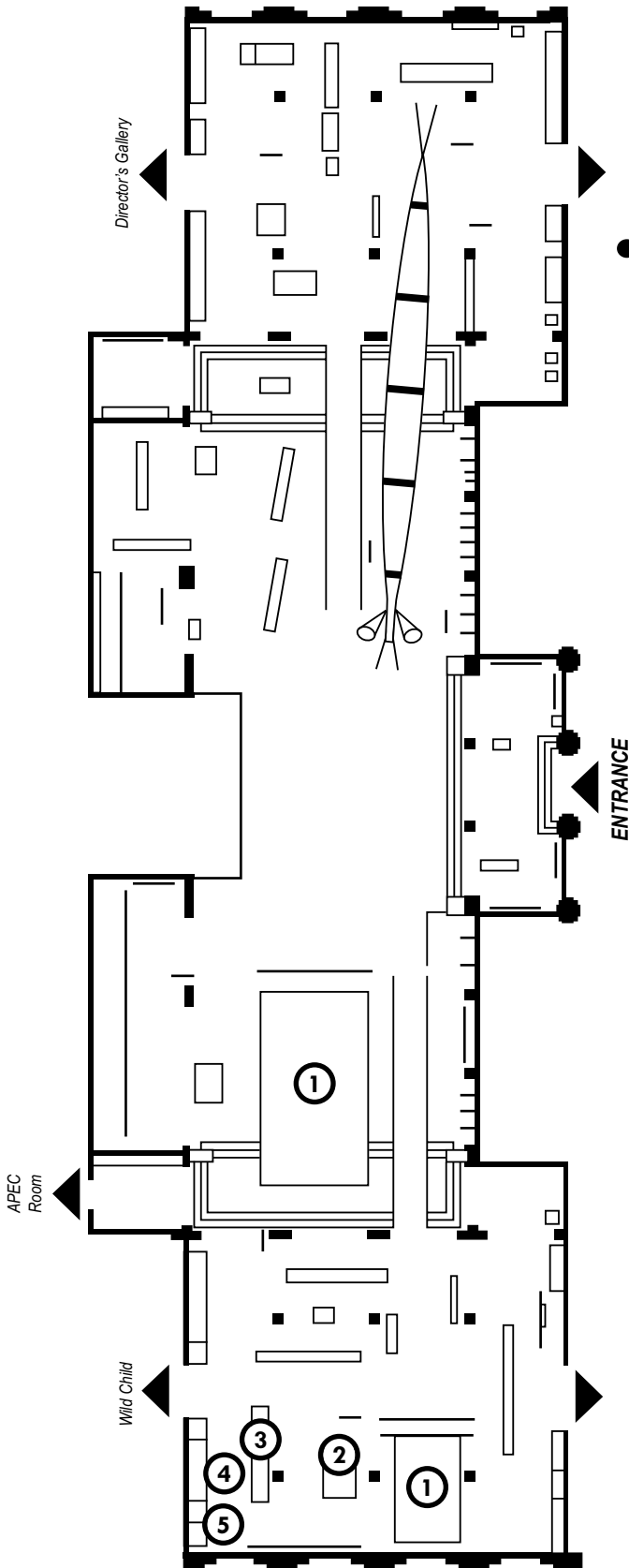

MAORI GALLERY
GROUND FLOOR

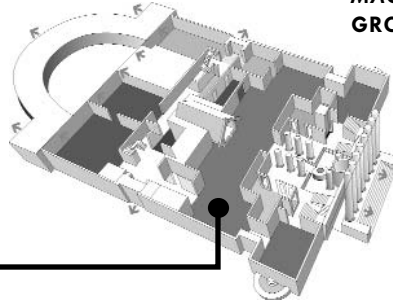

MAORI NATURAL
HISTORY GALLERY
FIRST FLOOR

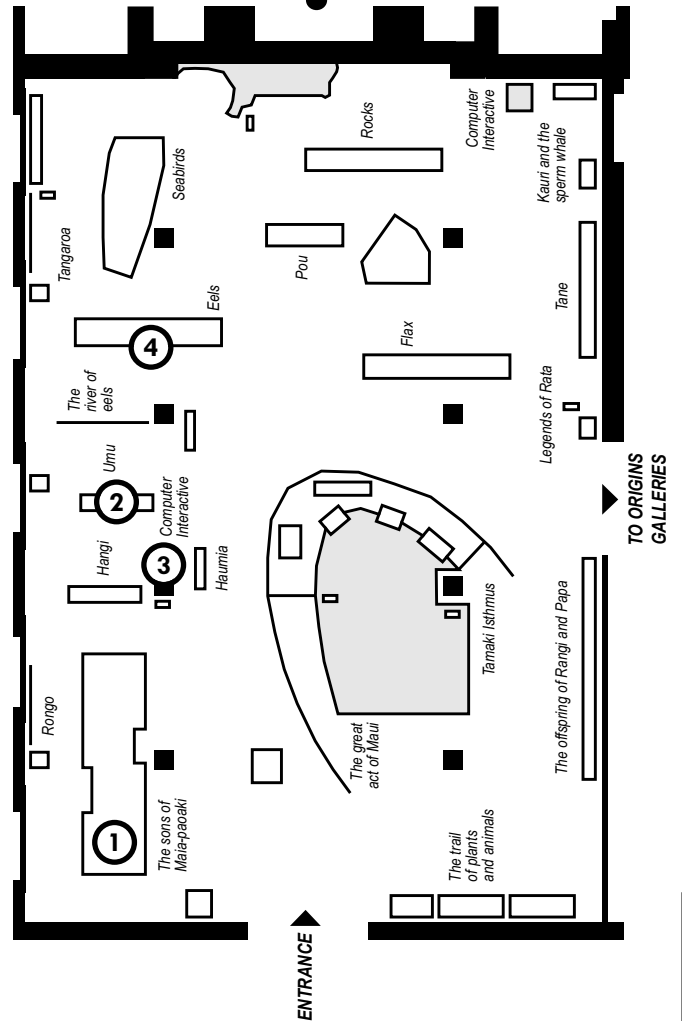
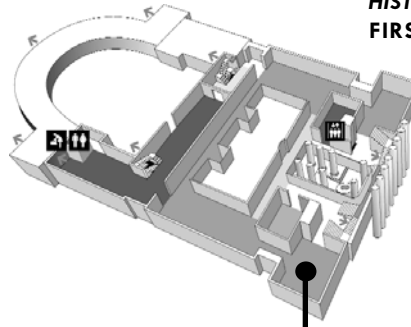

Gallery Activity Sheet Y4-6

te mahi kai

M AORI GALLERIES (GROUND FLOOR)

1. Pataka

This building was used by Maori to store certain foods in.

Why is it on stilts above the ground? _____

2. Pa model

Find:

- people fishing
- an animal that could be used to help hunt birds
- crops growing, what do you think they are growing? _____

3. Fishing

Draw something that could be used to catch fish. What is it called? Describe how it worked and what it was made out of.



4. Birding

Draw a bird trap. What is it called? Describe how it worked and what it was made out of.



te mahi kai

Gallery Activity Sheet

Y4-6



5. Gourd

Birds were stored inside gourds. How was the gourd decorated to show what it contained?

What else could you use a gourd for?

MAORI NATURAL HISTORY GALLERY (TE AO TUROA - MIDDLE FLOOR)

1. Kumara do not grow all year round in New Zealand. How did Maori store them over winter?

What other plants did Maori grow? _____

Find a stone figure which was to help the crops grow well. Who do you think it is of?

2. Hangi

Hangi were used to cook food. What heats the hangi? _____

What adds the salt flavour in this hangi? _____

3. Fire

Watch the fire video to see how the fire was made to heat the stones that cooked the hangi.

4. Fresh water fish

Look in the running stream to find a live animal that Maori ate.

Continue into the rest of the Natural History Gallery to find a very big bird that was eaten by Maori.

Gallery Activity Sheet **Y 4-6**

te mahi kai

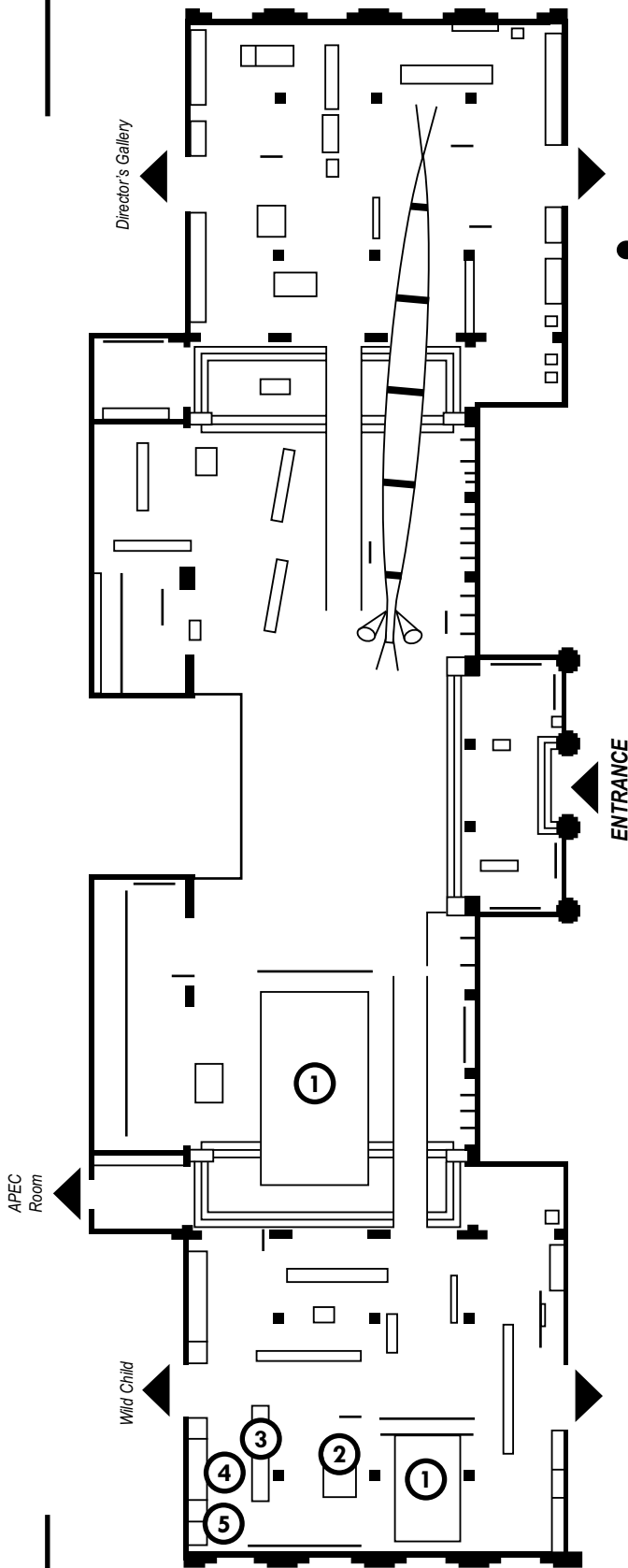

**MAORI GALLERY
 GROUND FLOOR**

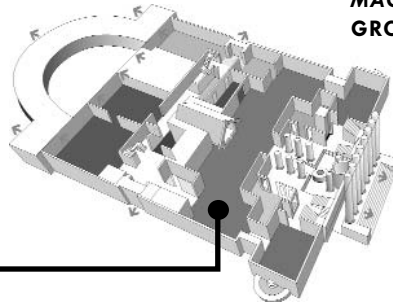

**MAORI NATURAL
 HISTORY GALLERY
 FIRST FLOOR**

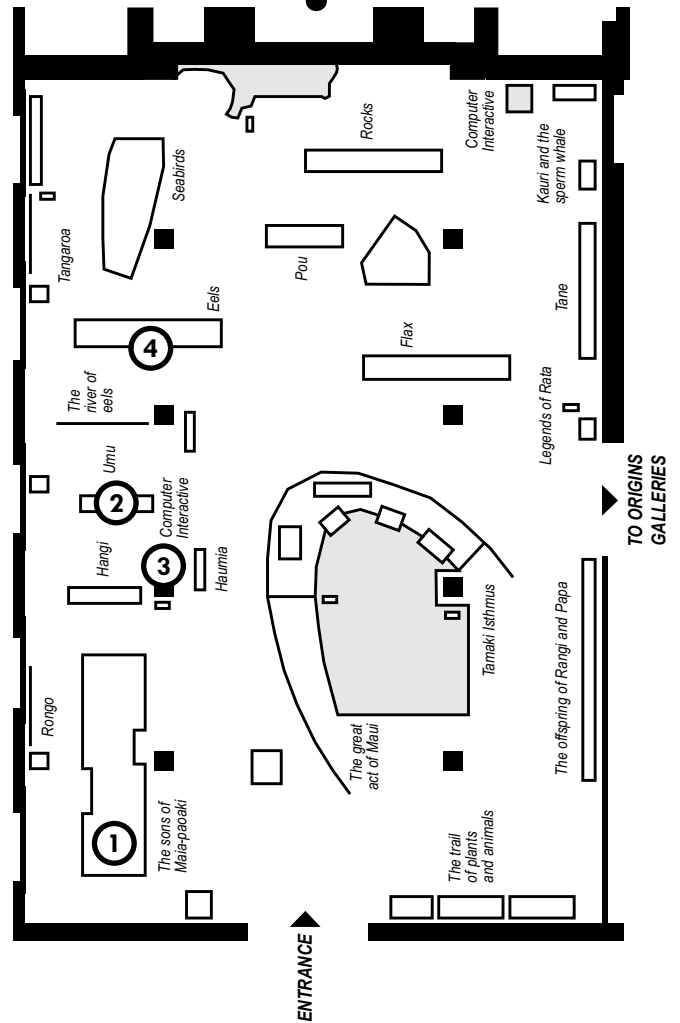
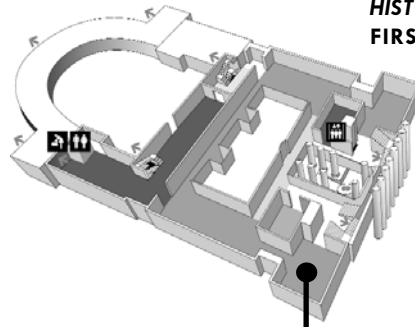

te mahi kai

Gallery Activity Sheet

Y 7-10

M AORI GALLERIES

1. Pataka

This building was used by Maori to store certain foods in. Why is it on stilts above the ground?

2. Pa model

What activities can you find that show people gathering and preserving food?

3. Fishing

Draw a fish trap. Name it, describe how it works and what is it made of.



4. Birding

Draw a bird trap. What is it called? Describe how it works and what it was made out of.



Gallery Activity Sheet

Y 7-10

te mahi kai



5. Gourd

Birds were stored inside gourds. Why was it important that the birds were cooked before being placed in the gourd?

MAORI NATURAL HISTORY GALLERY (TE AO TUROA - MIDDLE FLOOR)

1. Kumara was one of the plants that were brought to New Zealand by Maori and survived. Normally they do not grow in such a cold country. How were they kept alive over the winter months?

What other plants were brought to New Zealand by Maori?

What evidence can you find that suggests Maori called on gods to help crops grow?

2. Hangi

Hangi cook food using steam. How is the steam made?

3. Fire

Watch the fire video. How was fire made to heat the stones for the hangi?

4. Continue into the rest of the Natural History Gallery. What large land animal provided food for the first Maori who came to New Zealand?

What could the other parts of its body have been used for?

te mahi kai

Gallery Activity Sheet

Y 7-10

MAORI GALLERY
GROUND FLOOR

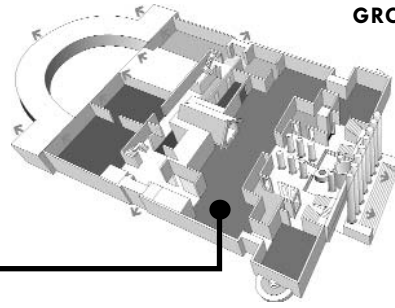

MAORI NATURAL
HISTORY GALLERY
FIRST FLOOR

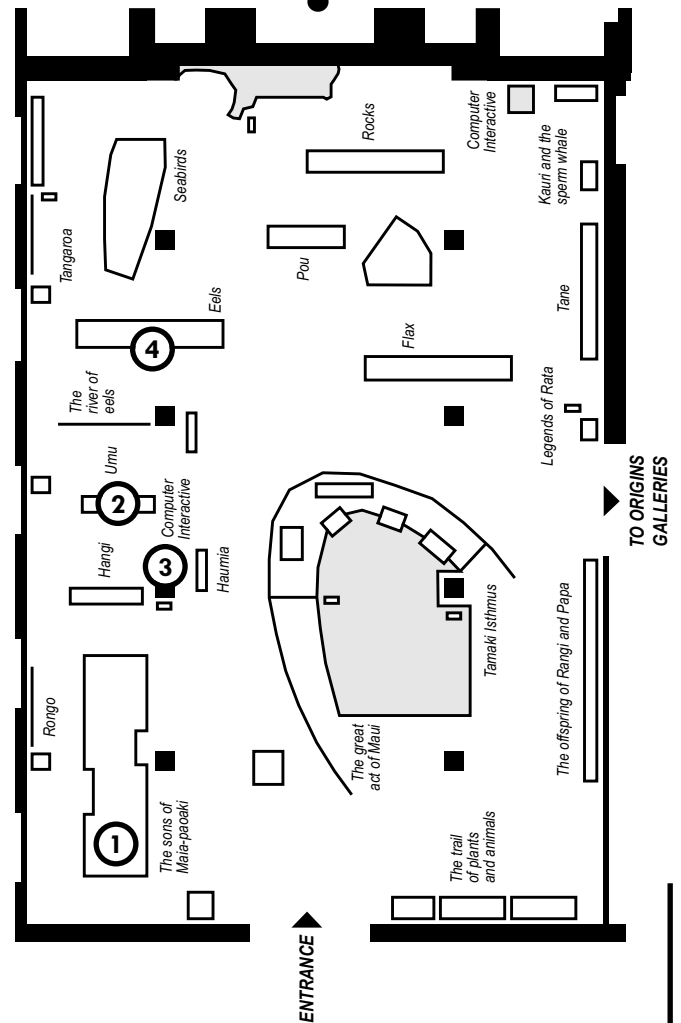
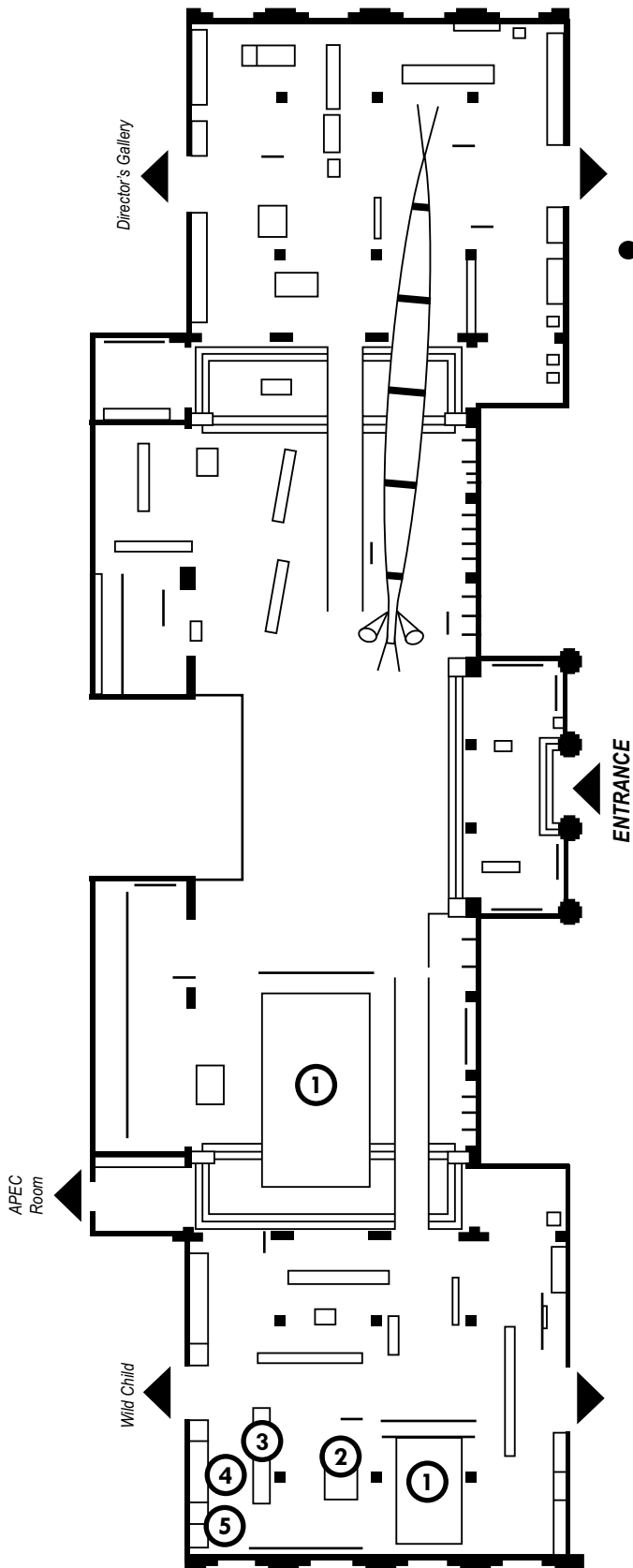
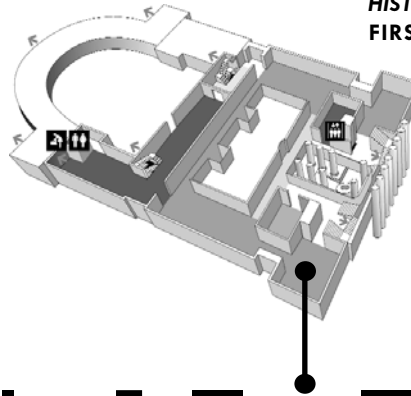

Recorded information: (09) 306 7067
Administration: (09) 309 0443 Fax (09) 379 9956
School Bookings: (09) 306 7040 Fax (09) 306 7075
Email: schools@aucklandmuseum.com

www.aucklandmuseum.com

AUCKLAND MUSEUM
The Domain Auckland
Private Bag 92018 Auckland New Zealand

